

DRIVING OLD CARS

BUILDING AN OLD CAR LIBRARY-

“Research Before You Restore”

By *Bin Johnson* PUBLISHER

Before buying a car, I always buy as much relevant literature as possible. This includes owner's, motors, body and parts manuals and color chips. I also search for drive reports, service bulletins and factory updates. Much of the above is available in print and on CD's from vintage book stores and online.

One of the reasons for putting together my library, was I had gotten tired of buying useless parts that were *supposed* to work and *didn't*; parts that will end up on eBay one day because I didn't have all the correct information before buying them. Ultimately, it is my responsibility to know exactly what I need, and if one part *really* does fit “all” applications. I am always skeptical when someone tells me “don't worry about it—I know what you need.” I remember being told that when I bought a set of classic-styled radiator hose clamps for my '48 Packard Custom 8. When I got them, they looked great! But they didn't fit—they were too small. Belatedly, I checked my parts book, which listed the correct size. I had wasted time and money by *not looking them up first*. In 40+ years of restoring, one lesson I have learned is DO YOUR OWN RESEARCH!

Among my favorite books for part numbers and research are the Flat Rate/Part Number Books. I have a two-volume set covering cars from the eras we restore: 1935-1954. Book One covers 1935-1941 and Book Two covers 1940-1954. These books show not only part numbers, but pictures, sizes and dimensions for such parts as brake linings, seals, bearings, wheel cylinders, etc. They were invaluable during our mechanical restoration on our '53 Roadmaster 2 dr. Hardtop. The engine was a real challenge in that it was a first-year engine and changes were made throughout the year. I bought the 1952 and 1953 factory manuals (you need them both) to study before I bought the car, but found that Buick's “Product Service Bulletin” manual was where I found all of

the upgrades to make the car run at its best. When the first '53 Roadmasters and Supers rolled off the assembly line, they were fitted with high dome pistons.* The '53's first issue pistons measured 2.578” This measures from the center of the piston pin to the top of the piston dome, compared with a measurement of 2.180” on the '54 pistons—a difference of .398”! Our '53 had its original 322 V8 engine, but when we took it apart, it had low-dome '54 pistons and heads, and curiously, the block had never been bored, leaving us to believe it

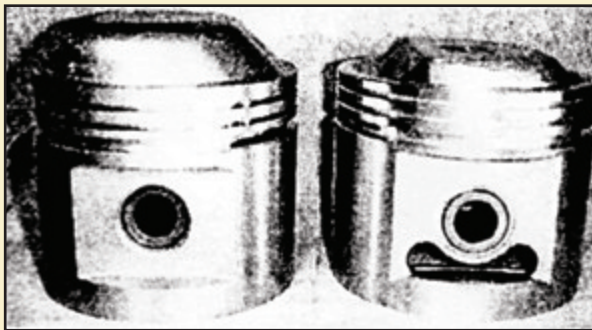

'53 & '54 BUICK PISTONS

was a late year change, or a dealer change. But why did Buick change piston designs? Again, back to the books. We found a drive report by a legendary test driver/reporter of the day. It showed him making a cross-country test run in a '53 Buick Super V8. He gave high praise to the car's overall performance, but stated there was "pinging and

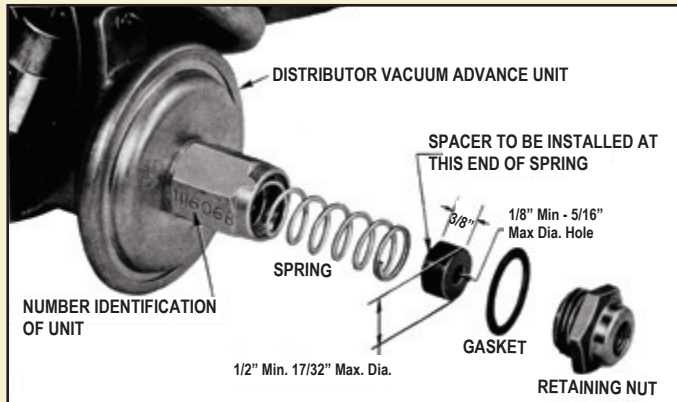

'53 BUICK R/M VACUUM ADVANCE

spark rap during acceleration." This was published in a well-read magazine of the time and could have led to the piston design change, but further reading in Buick's "Product Service Bulletin" manual, they reported mild to moderate spark rap with a pinging sound during acceleration, and listed the first issue vacuum advance as a possible cause. Buick's remedy was to issue a new vacuum advance with a 3/8" long spacer between the vacuum advance unit spring and the spring retaining nut on the distributor. This was done to lower the maximum spark advance. It also stated that the spacer was to be used in vacuum advance #1116068 and not to be used under any circumstances in vacuum advance #1116083. These kinds of details clearly matter on performance. I recently saw a GM Delco-Remy NOS vacuum advance on eBay listed for '53-'56 Buicks "all." Before I ordered it, I would want to know what the part number is and if it is a #1116083, to make sure the spacer had not been added. Another problem that could have been prevented on our '53 was not to run the engine without an ignition (ballast) resistor.** The previous owner said he had just tuned the car and had gone through the entire ignition system. When we were checking the car in, we were inside with the key on, when suddenly we saw smoke! A fire had started at the coil, which is of course, right next to the glass bowl AC fuel filter at the carburetor. Fortunately, we got the fire out before doing much damage, but not before melting some wiring, blowing up the coil and melting the distributor cap! After a stiff Diet Coke, we checked our wiring diagram and saw that the ignition resistor had been left out of the ignition system. We added one (they're only about \$10 for a NORS one) but the real cost was replacing everything else. A review of the wiring schematic when we brought the car in would have prevented the entire problem. I now have read all 180 pages in the "Product Service Bulletin" for '53 Buicks, and I can tell you, it is easier to read about the changes the factory made, than for me to work them out in the shop!

I recently read a Packard story about a collector who bought a beautifully restored 1930's Packard Super 8. Now, Packard straight 8's originally used slotted

spark rap during acceleration." This was published in a well-read magazine of the time and could have led to the piston design change, but further reading in Buick's "Product Service Bulletin" manual, they reported mild to moderate spark rap with a pinging sound during acceleration, and listed the first issue vacuum advance as a possible cause. Buick's remedy was to issue a new vacuum advance with a 3/8" long spacer between the vacuum advance unit spring and the spring retaining nut on the distributor. This was done to lower the maximum spark advance. It also

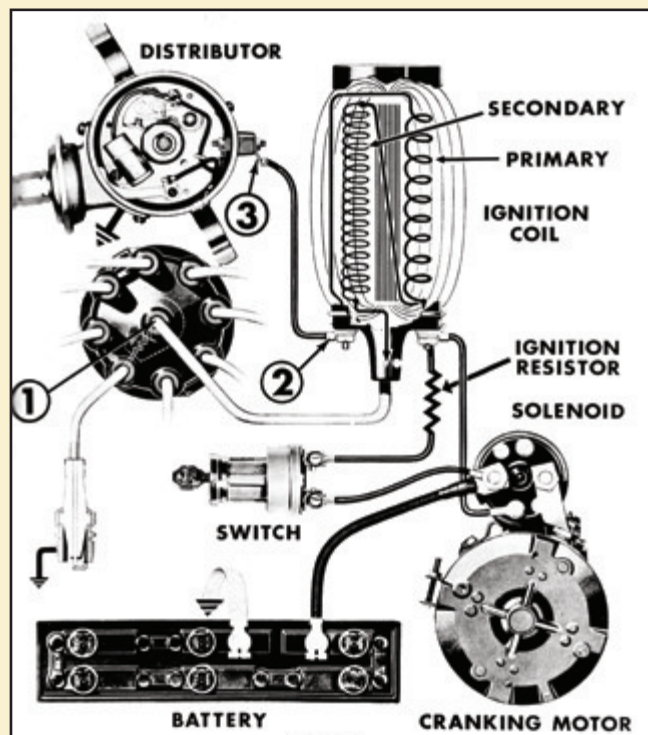

'53 BUICK R/M IGNITION SYSTEM

Continued ➞

